

TECHNICAL MANUAL

OPERATOR'S, ORGANIZATIONAL, DIRECT SUPPORT
GENERAL SUPPORT MAINTENANCE MANUAL
SEMIAUTOMATIC MESSAGE
DISTRIBUTION SYSTEM
SAMS

HEADQUARTERS, DEPARTMENT OF THE ARMY

NOVEMBER 1971

NOT AVAILABLE THRU
A.G. PUBLICATION
CHANNELS. MSC CON-
TROLLED ONLY

PROPRIETARY NOTICE

This technical data, furnished under United States Government Contract No. DAHC 07-71-C-0061, shall not, without the written permission of The Bendix Corporation, be either (a) used, released or disclosed in whole or in part outside the Government, (b) used in whole or in part by the Government for manufacture or (c) used by a party other than the Government, except for: (i) emergency repair or overhaul work only, by or for the Government, where the item or process concerned is not otherwise reasonably available to enable timely performance of the work, provided that the release or disclosure hereof outside the Government shall be made subject to a prohibition against use, release, or disclosure; or (ii) release to a foreign government, as the interest of the United States may require, only for information or evaluation within such government or for emergency repair or overhaul work by or for such government under the conditions of (i) above. This legend shall be marked on any reproduction hereof in whole or in part.

i/(ii blank)

Technical Manual)
)
 No. 32-7440-209-15)

HEADQUARTERS
 DEPARTMENT OF THE ARMY
 WASHINGTON, D.C., 9 November 1971

**OPERATOR'S ORGANIZATIONAL, DIRECT SUPPORT, GENERAL SUPPORT
 MAINTENANCE MANUAL
 SEMIAUTOMATIC MESSAGE DISTRIBUTION SYSTEM (SAMDS)**

Paragraph		Page
	INTRODUCTION	vii
SECTION 1. GENERAL INFORMATION		
1-1	General.....	1-1
1-3	Purpose	1-1
1-5	Functional Description.....	1-1
1-10	Physical Characteristics	1-2
SECTION 2. INSTALLATION AND OPERATION		
2-1	General	2-1
2-3	Unpacking	2-1
2-5	Installation	2-1
2-7	External Connections	2-1
2-10	Programming	2-1
2-13	Program Modules	2-4
2-16	Operation	2-5
SECTION 3. PRINCIPLES OF OPERATION		
3-1	General	3-1
3-3	Circuit Card Family	3-1
3-12	Logic Modules	3-1
3-14	Notation	3-2
3-16	General Theory of Operation	3-2
3-18	Counters	3-3
3-19	Oscillator Count-Down	3-3
3-20	Bit Counter	3-3
3-24	Character Counter	3-4
3-27	Program Position Counter	3-4
3-28	Register	3-4
3-31	Selector Control	3-5
3-38	Turret Controls	3-6
3-44	Program Card Use	3-7
3-47	Input/Output Control	3-7
3-51	Power Supplies	3-8
SECTION 4. MAINTENANCE		
4-1	General	4-1
4-3	Test Equipment.....	4-1
4-5	Repair Instructions.....	4-1
4-7	Performance Tests	4-1
4-9	Troubleshooting	4-2

TABLE OF CONTENTS (Cont)

Paragraph Page

SECTION 5. PARTS LISTS

5-1 INTRODUCTION 5-1

SECTION 6. DRAWINGS

6-1 General..... 6-1

LIST OF ILLUSTRATIONS

Number	Title	Page
1-1	Semiautomatic Message Distribution System (SAMDS)	1-0
2-1	External Connection Diagram	2-2
2-2	System Interconnecting Diagram	2-3
2-3	Layout of A12 Printed Circuit Card	2-4
2-4	Turret Control Panel	2-6
2-5	SAMDS Program Format	2-7
3-1	Data-Clock Relationship	3-2
6-1	Schematic, Semiautomatic Message Distribution (2 Sheets)	6-3
6-2	Logic Diagram, Timing Control	6-7
6-3	Schematic, Expander A4All Printed Circuit Board	6-9
6-4	Schematic, Polar Signal Interface Printed Circuit Board	6-10
6-5	Logic Diagram, Channel Control	6-11
6-6	Schematic, Circuit Cards A1 Through A10	6-13

LIST OF TABLES

Number	Title	Page
1-1	Design Characteristics of SAMDS	1-2
4-1	Troubleshooting Chart	4-2
5-1	Parts List	5-2

DEFINITIONS AND ABBREVIATIONS

Bit: A bit is a contraction of the term "binary digit." The binary digit is an information state (1 or 0) in binary notation,

Baud: The baud is the unit of modulation rate. One baud corresponds to a rate of one unit interval per second. The modulation rate is expressed as the reciprocal of the duration (in seconds) of the unit interval: for example, if the duration of the unit interval is 20 milliseconds, the modulation rate is 50 baud.

Logic Levels: Logic Levels for digital data intelligence may be said to be at either a "1" or "0" level. A "1" level is the higher magnitude and a "0" level is the lower magnitude. For this equipment, the higher magnitude level is +5 volts and the lower magnitude level is zero volts or ground.

Polar Levels: Input and output interface levels are polar voltage levels. A polar logic level refers to those signals whose maximum voltage levels are positive with respect to ground reference and have minimum levels which are negative with respect to ground. In this system the input interface polar level for logic "1" is from +0.5 to +7.0 volts and for a logic "0" from -0.5 to -7.0 volts. The output interface polar level for a logic "1" is +6 volts \pm 1 volt. For a logic "0" it is -6 volts \pm 1 volt.

DTL: Diode-Transistor Logic

TTL: Transistor-Transistor Logic

Vcc: Supply voltage to module

Interface Circuits: Bendix IC modules are used to meet MIL-STD-188C requirements. These modules are Bendix proprietary items designed specifically for interface use and meet or exceed MIL-STD-188C. The Bendix μ E251A is a low-level polar driver and the IE235B is a low-level polar signal detector or input amplifier.

v/(vi blank)

INTRODUCTION

GENERAL.

This instruction manual contains installation, operation and maintenance instructions for a Semiautomatic Message Distribution System (SAMDS) (part number 4031471-0501). The equipment described herein is a proprietary item designed and fabricated by The Bendix Corporation, Communications Division, Baltimore, Maryland 21204.

SCOPE OF MANUAL.

The information presented in this manual is intended for use by an electronics maintenance technician who is familiar with teletype systems and knowledgeable in the area of digital logic circuitry. A brief description of the contents of the manual is as follows:

- a. Section 1, States purpose and general description of SAMDS and physical characteristics.
- b. Section 2, Installation, programming, and operation instructions.
- c. Section 3, General theory of operation, circuit and logic explanations, circuit board family, logic modules and notations are explained.
- d. Section 4, Maintenance, troubleshooting information.
- e. Section 5, Contains the list of all electrical parts in the SAMDS system.

RELATED PUBLICATIONS.

Technical publications which may be useful when used in conjunction with this instruction manual are as follows:

MIL-STD-12C - Abbreviations for Use on Drawings, Specifications, Standards and in Technical Documents

MIL-STD-15 - Graphical Symbols for Electrical and Electronic Diagrams

MIL-STD-16 - Electrical and Electronic Reference Designations

MIL-STD-806B - Graphical Symbols for Logic Diagrams

MIL-STD-188C - Military Communication System Technical Standards

DCAC 300-175-1-DCA Engineering- Installation Criteria.

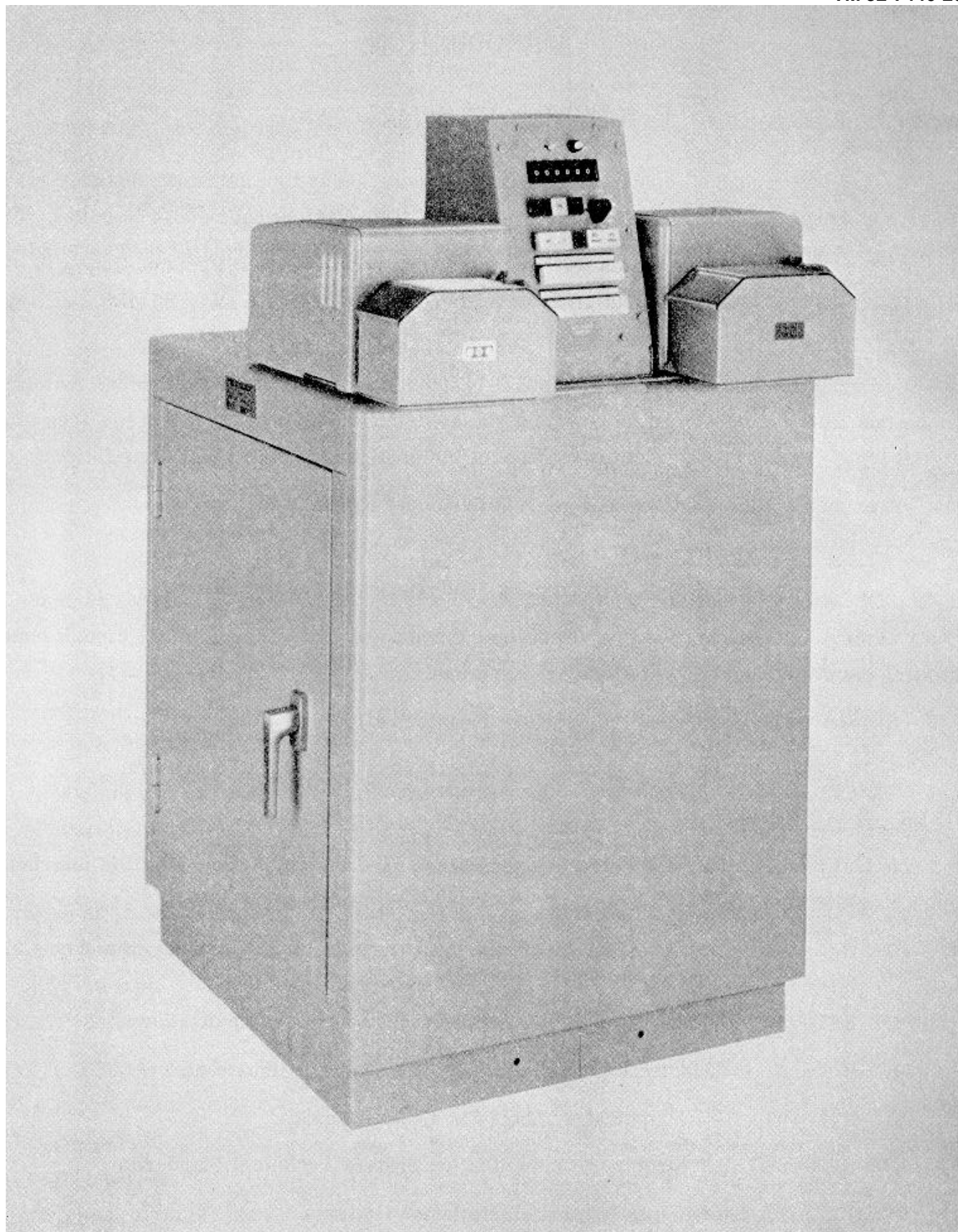

Figure 1-1. Semiautomatic Message Distribution System (SAMDS)

SECTION 1 GENERAL INFORMATION

1-1. GENERAL.

1-2. This section briefly states the purpose and contains a general description of the Semiautomatic Message Distribution System, hereinafter referred to as SAMDS (see figure 1-1).

1-3. PURPOSE.

1-4. The purpose of SAMDS is to provide the means to distribute locally, up to 10 copies of a taped message simultaneously to the addressed Page Printers. Any, or all, system addresses may be selected for receipt of the input tape message.

1-5. FUNCTIONAL DESCRIPTION.

1-6. The SAMDS input is a teletype message tape-loaded into one of the two Transmitter Distributor (TD) units mounted on top of the cabinet. After clearing the unit, the operator chooses the Action Address (AA) and then up to nine Information Addresses (II); the Keyboard (KB) associated with the unit may be used in the AA position or in the last II position, to add addresses or information not included in the ten wired-in addresses.

1-7. If a mistake is made during address selection, an Erase (ERASE) button allows the operator to erase any selections one at a time, without disturbing other selections previously made.

1-8. Each address may contain up to seven characters in any alphanumeric combination. The addresses are user-programmed using character modules in sockets on the program cards, one program card is used for each of ten addresses and three are used for program output (CR, CR, LF etc.).

1-9. Once the SAMDS program is completed step pulse is fed to the selected TD until the tape message is complete. End of message (EOM) is recognized when no start pulses appear for at least sixteen step-pulse inputs, then the TD light goes out and step-pulse is stopped. It should be noted that a tight-tape or a broken-tape situation may yield the markhold signal used to detect EOM and therefore necessitate a complete restart; these conditions must be avoided.

1-10. PHYSICAL CHARACTERISTICS.

1-11. Physical characteristics of the SAMDS are listed in table 1-1.

Table 1-1. Design Characteristics of SAMDS

MECHANICAL

Dimensions	22 inches D x 40-5/8 inches H x 24-1/16 inches W
Volume	12.4 cubic feet
Weight.....	210 pounds

ELECTRICAL

Power (Both TD's on)	11 amperes at 117 Vac
Input Signals	±0.5V
Output Signals	±6V to 10 mA
Data Rate	Internally, 75, 150, 300, 600, 1200, 2400, 4800 baud and an external clock input

1-12. Physical configuration and dimensions of the SAMDS as shown in figure 6-1.

SECTION 2

INSTALLATION AND OPERATION

2-1. GENERAL.

2-2. This section contains instructions for installation, programming and operation of the SAMDS.

2-3. UNPACKING.

2-4. Carefully unpack the equipment and inspect for damages. In case of transit damage, notify the carrier company immediately.

2-5. INSTALLATION.

2-6. The SAMDS console unit is desk-top high from the floor with turret controls and TD tape handlers within easy reach of a seated operator. For convenience it is recommended that the equipment be therefore located near the associated keyboard and monitor page printer. Locate motor start units near their associated page printer using MC110 manual as a connection guide.

2-7. EXTERNAL CONNECTIONS.

2-8. Power connections are made on terminal strip A5TB1 located on the rear of the power supply rack; number 14 wire, or larger, should be used for power cable since it may have to carry up to 11 amperes.

2-9. Signal connections are made on the tag block TB1 located behind the card cages. Wire of a size suitable for carrying 10 mA should be used for the signal connections. The external connection diagram, figure 2-1, shows the tag block terminal assignments and System Interconnection diagram, figure 2-2, shows the overall system configuration.

2-10. PROGRAMMING.

2-11. The A12 cards located in the lower card cage positions XA22 through XA31 provide the means to program the ten subscriber address notations. The layout for the A12 printed circuit card is shown in figure 2-3. Each card contains seven sockets for holding up to seven program modules. The socket order A1 through A7, on each card, is the output sequence order. Letter and figure shifts desired must be included in the seven characters. An unprogrammed position yields a letters character output.

K	G		G		G		G		G		G		SG	SG	SG	SG	SG	SG	SG	SG
J	STEP TO TD1		TD1 OUT		STEP TO TD2		TD2 OUT		TD STEP OUT		TD IN		SG	SG	SG	SG	SG	SG	SG	SG
H													SG	SG	SG	SG	SG	SG	SG	SG
G	G		G		G		G		G				SG	SG	SG	SG	SG	SG	SG	SG
F	MON OUT		EXT CLK IN		DATA CLK OUT		STEP TO KBD		KBD IN											
E																				
D	G	G	G	G	G	G	G	G	G	G										
C	CHAN 1 READY	CHAN 2 READY	CHAN 3 READY	CHAN 4 READY	CHAN 5 READY	CHAN 6 READY	CHAN 7 READY	CHAN 8 READY	CHAN 9 READY	CHAN 10 READY										
B	G	G	G	G	G	G	G	G	G	G										
A	CHAN 1 OUT	CHAN 2 OUT	CHAN 3 OUT	CHAN 4 OUT	CHAN 5 OUT	CHAN 6 OUT	CHAN 7 OUT	CHAN 8 OUT	CHAN 9 OUT	CHAN 10 OUT										
	1	2	3	4	5	6	7	8	9	10	11	12	13	14	15	16	17	18	19	20

TBI

Figure 2-1. External Connection Diagram

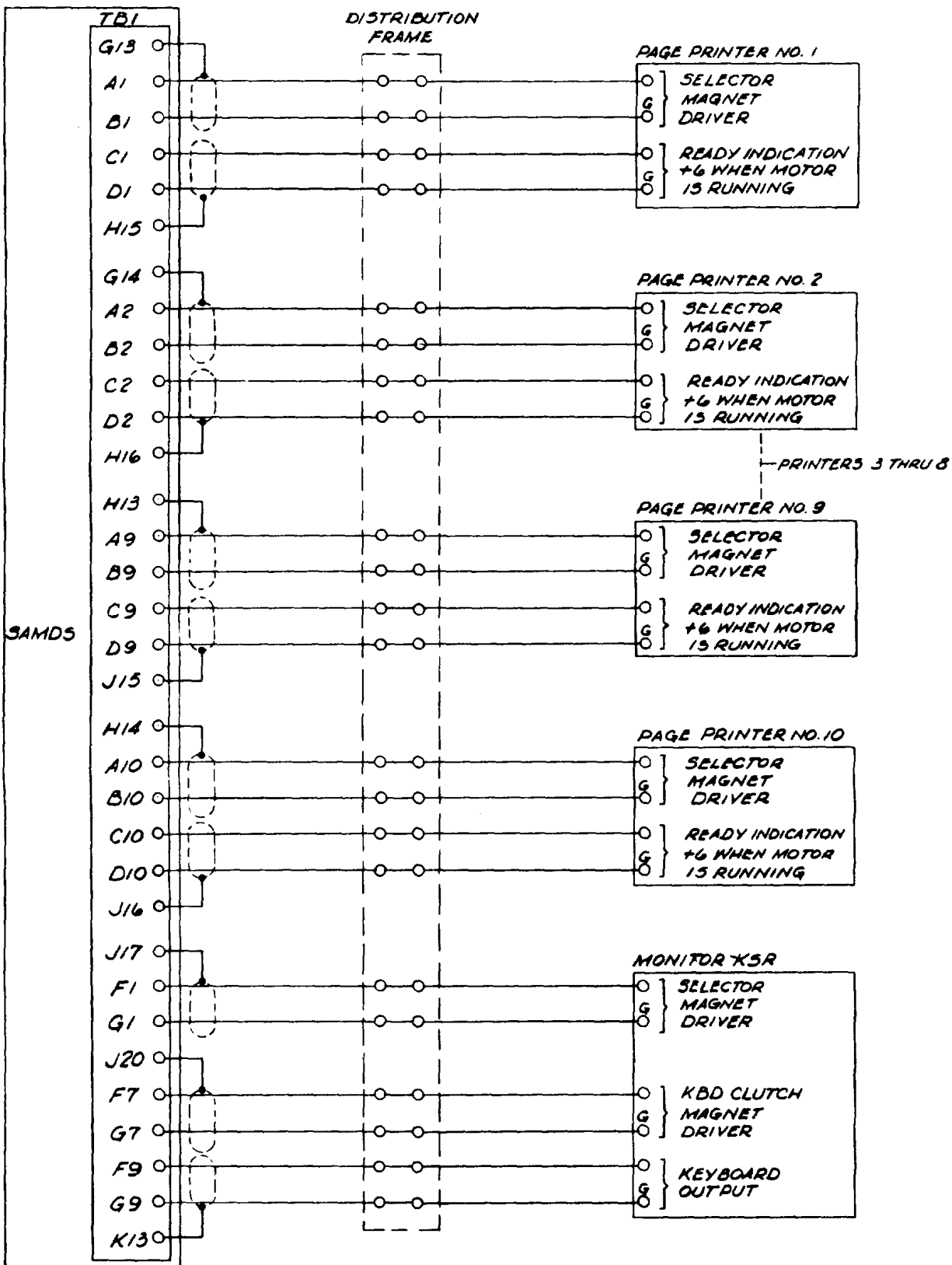

NOTE: Terminal Designations are not given for the page printers and the KSR since this information is different from the various models that may be used.

Figure 2-2. System Interconnecting Diagram

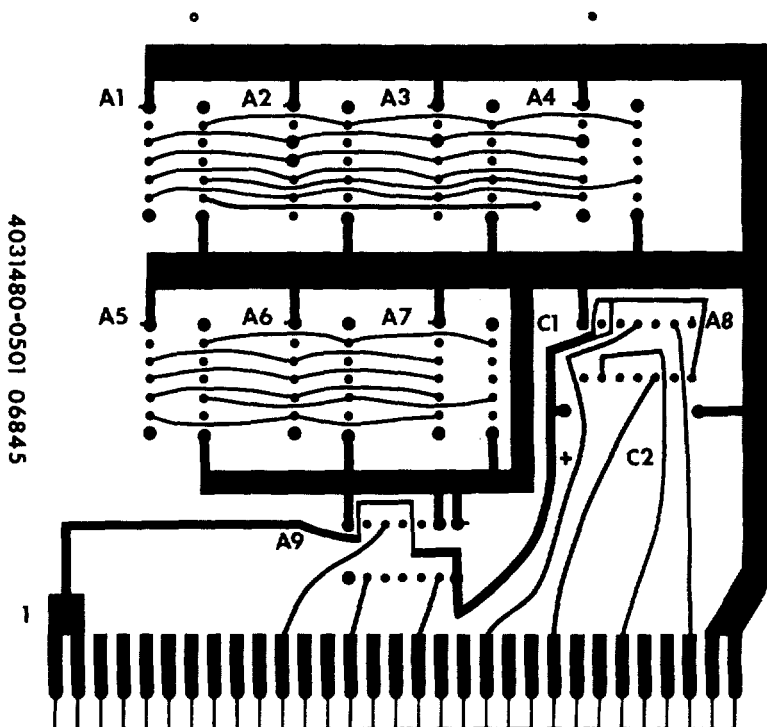

Figure 2-3. Layout of A12 Printed Circuit Card

2-12. The card in the lower left end position (XA22) is selected by the upper left Page Printer Address button (S1), the adjacent button (A2) selects the second card from the lower left, etc. The lower left Page Printer Address button (S6) selects the card in the sixth position from the lower left (XA27), etc.

2-13. PROGRAM MODULES. The program module is a Signetics Corporation N8731A diode cluster in a 14 pin DIP integrated circuit package. Each module can generate two characters. A plastic strip has been added on top of the module for noting the symbols of the characters which the module generates.

2-14. Programming modules consists of cutting the pins leading to the character-bit positions containing marks (1); pins left uncut will generate a space (0) in their bit position.

Since module pins 10 and 3 are used in both orientations, the first character programmed into a module partially determines what the alternate character may be; care must therefore be exercised when choosing the alternate character to ensure that module pins 3 and 10 are

compatible to both characters (either orientation). Outline sketches of the program module are shown on the left end of the Logic Diagram, Timing Control next to the program card schematic (see figure 6-2).

2-15. The symbol for the character programmed should be inked on the plastic strip and should agree with the proper orientation of the module; the desired character symbols should stand correctly upright and agree with the socket component lettering orientation on the printed circuit card while the unused portion of the strip should be blank or contain an inverted symbol.

2-16. OPERATION.

a. Turn on the SAMDS using the switch located on the front of the power supply rack; the TD power switch(es) should be ON. The power indicator lamp located adjacent to the switch and the power indicator lamp on the turret control panel should both be lit.

b. Depress the CLEAR button and see that the lamp remains lit when the button is released; all other operating indicators should be extinguished. Push again and hold longer if CLEAR does not remain on or if other indicators remain on. The SAMDS Turret Control Panel is shown in figure 2-4.

c. Insert the message tape into the TD selected by the switch located on the turret panel. Number one TD is to the left and number two to the right of the turret when facing the control panel.

d. Depress the AA button and observe that it remains lit when the button is released; if the lamp extinguishes, return to step b.

e. Depress the Page Printer Address selector button for the desired action address and see that the lamp remains lit when the button is released; if the lamp extinguishes, depress again and hold longer before releasing. A sluggish motor start unit and/or slow starting motor should not cause the delay to exceed two seconds.

f. Depress the II button.

g. Depress Page Printer Address selector button for all the information addresses desired, in any order.

h. If an undesired address selection is made first, hold the ERASE button in the depress position; all Page Printer Addresses selector lamps will extinguish. Second, depress the undesired Page Printer Address button; the lamp will glow momentarily but will extinguish when the button is released. Third, release the ERASE button; all previously selected Page Printer Address lamps will relight except the undesired one.

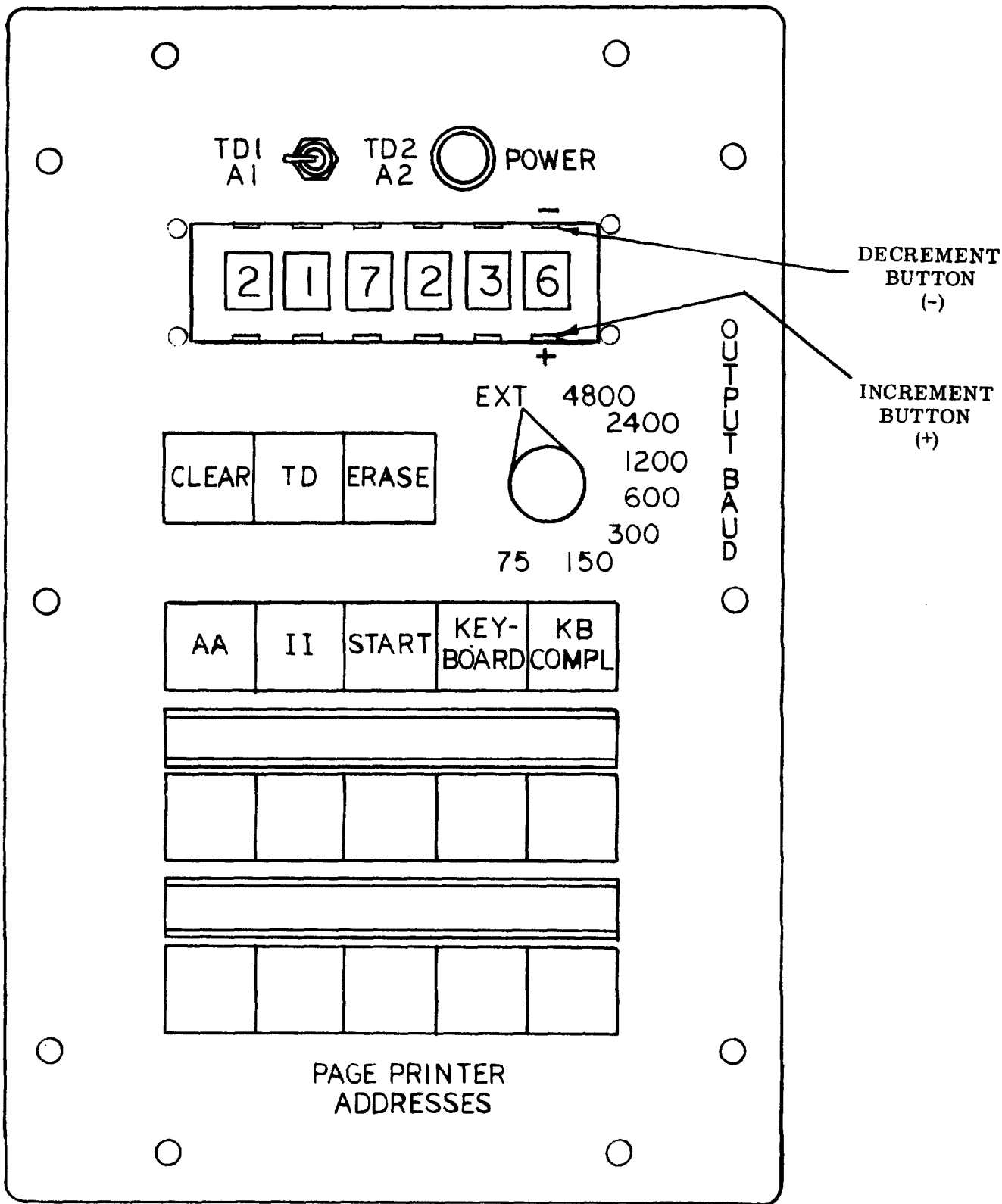

051-002-011

Figure 2-4. Turret Control Panel

		CHARACTER COUNTER															
		1	2	3	4	5	6	7	8	9	10	11	12	13	14	15	16
PROGRAM POSITION COUNTER	1	LS	CR	CR	LF	I	N	N	R	SP	FS	0	1	2	3	4	5
	2	LS	CR	CR	LF	A	A	SP	X	X	X	X	X	X	X	SEE NOTE	
	3	LS	CR	CR	LF	I	I	SP	X	X	X	X	X	X	X		
	4	LS	CR	CR	LF	SP	SP	SP	X	X	X	X	X	X	X		
	5	LS	CR	CR	LF	SP	SP	SP	X	X	X	X	X	X	X		
	6	LS	CR	CR	LF	SP	SP	SP	X	X	X	X	X	X	X		
	7	LS	CR	CR	LF	SP	SP	SP	X	X	X	X	X	X	X		
	8	LS	CR	CR	LF	SP	SP	SP	X	X	X	X	X	X	X		
	9	LS	CR	CR	LF	SP	SP	SP	X	X	X	X	X	X	X		
	10	LS	CR	CR	LF	SP	SP	SP	X	X	X	X	X	X	X		
	11	LS	CR	CR	LF	SP	SP	SP	X	X	X	X	X	X	X		
	12	LS	CR	CR	LF	SP	SP	SP	X	X	X	X	X	X	X		
	13	LS	CR	CR	LF	K	B	KB	K	B	K	B	SEE NOTE				
	14	LS	CR	CR	LF	DELAY			SOM								
EOM																	
STOP STEP PULSE																	

051-002-012

NOTE:

The Keyboard (KB) may be used in AA or the final II positions. When these selections occur, the KB is sent step-pulse and the operator may type until he depresses the Keyboard Complete (KBC) button and restores program control to SAMDS. If KB is used in both AA and II positions, KBC light will extinguish after use on AA and remain lit after use on II. If KB is used in only one position, KBC will remain lit after use.

Figure 2-5. SAMDS Program Format

i. Set the thumbwheels located near the top of the turret control panel, to the desired serial number. Push the (+) button to increment and the (-) button to decrement, (see figure 2-4). These number wheels are not mechanically linked, therefore each one must be incremented when necessary (i. e., incrementing from 9 to 10, requires manually incrementing both the units and tens wheels).

j. Depress the START button, observe that the monitor prints-out the format shown in figure 2-5.
2-17. The TD indicator lamp will light when step-pulses begin driving the selected TD and will remain lit until sixteen or more step-pulses are sent without an accompanying start-bit on the data line. This EOM detection extinguishes the TD lamp and disables step-pulse. Return to step b.

SECTION 3 PRINCIPLES OF OPERATION

3-1. GENERAL.

3-2. This section presents detailed circuit and logic explanations for the SAMDS. The circuit board family, logic modules and notation are explained and described. The general theory of operation is also presented in this section.

3-3. CIRCUIT CARD FAMILY.

3-4. The SAMDS is implemented with a circuit card family of several cards containing only a few modules each. There are sixteen card types including two cable cards (see section 5 Parts Lists).

3-5. Several of the cards are used in more than one position. The card type is noted on the logic diagrams along with its card cage location.

3-6. A4A1 Through A4A10. - A4A1 through A4A10 cards use identical printed circuit cards each with a different type of four identical modules determining the card type.

3-7. A4A11-Card A4A11 is a diode expander card and is shown in figure 6-3.

3-8. A4A12 - Card A4A12 is the program card explained earlier; its logic diagram appears at the left end of the timing control diagram (figure 6-2).

3-9. A4A13 - Card A4A13 is the polar signal interface card and is shown in figure 6-4. This card provides level shifting in both directions between logic levels and polar levels.

3-10. A4A14 - Card A4A14 is an auxiliary card containing a crystal oscillator operating at 4.9152 MHz, five voltage dropping diodes and ten biasing resistors (figure 6-2).

3-11. A4A15 and A4A16-Cards A4A15 and A4A16 are the cable cards.

3-12. LOGIC MODULES.

3-13. Logic modules used are all bipolar silicon semiconductor integrated circuits in fourteen pin dual-in line-packages (DIP). All modules except the register on A4A4, in position XA7 in the card cage, are the Signetics Corporation series N8000A in the silicon package for use at temperatures from 0°C to 70°C; the register mentioned is the National Semiconductor DM8570 and it also operates in the 0°C to 70°C range. The module types are listed in the parts list with the cards on which they are mounted.

3-14. NOTATION.

3-15. Each circuit element is shown on the logic diagram with its card type (A1 through A14) and its location (XA1 through XA42). The logic symbology follows MIL-STD-806 guidelines.

3-16. GENERAL THEORY OF OPERATION.

The timing control diagram (figure 6-2) of SAMDS shows a long counter chain which, in its longest configuration, can count to 134 million. This chain begins with a crystal oscillator running at 4. 9152 MHz. The oscillator rate is divided down to 75 Hz. All stages of these counters are usable as data clock but only the lower rates, from 75 Hz to 4800 Hz, are presented to the data rate switch. An external clock input is also presented to the data rate switch in the event the internal rates are not usable. The data rate chosen, internal or external, is the data clock for timing the SAMDS programmed portion of the output message and for timing the step-pulse character release signal for the external input devices (D's or keyboard). The chosen data clock is presented for use in polar form at the tag block terminal F5 and the return at G5. The data-to-clock relationship is shown in figure 3-1; this matches the phase of the external clock, if it is used. The bit counter formats the programmed characters by providing a start bit at the beginning of the character information bit release in proper order, and a stop bit at the end of the character. The character counter controls the order of characters in each line up to sixteen. The program position counter (PPC) keeps track of line order (see program format figure 2-5).

3-17. The Select Position Register (SPR) is initially cleared then steps at high-speedclock rate (307.2 kHz) until an AA is selected. It rests in the AA selected position until the START button is pushed and the AA address is read out in the second line. Once the AA has been read out, the PPC and the SPR step in tandem. Then both PPC and SPR step one

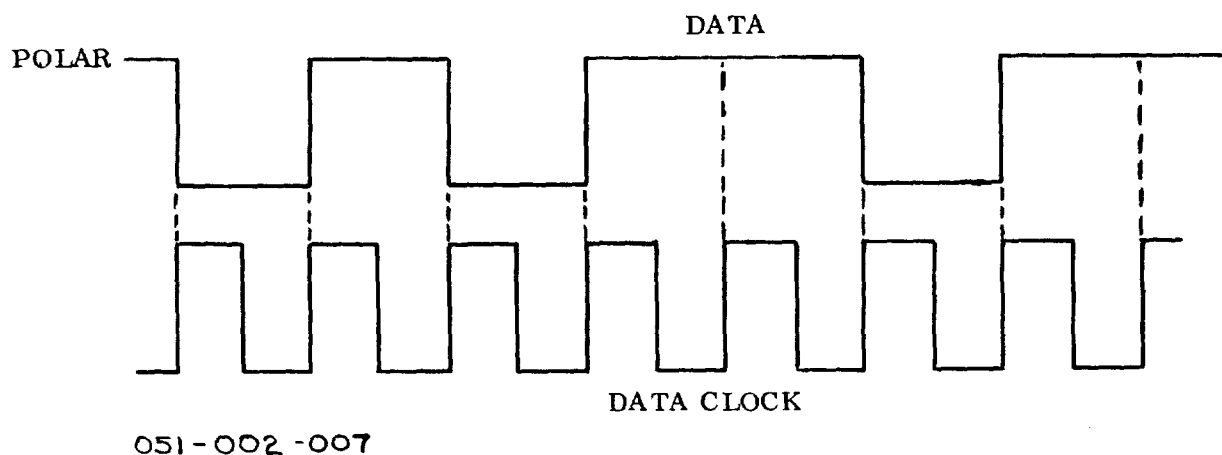

Figure 3-1. Data-Clock Relationship
3-2

position per line until the program position counter determines that the last line has been reached. If any address is not selected, its program position is skipped. A High Speed Clock (HSC) is used so that no delay or interruption of the output occurs. The HSC was made high enough to skip from position one to position ten without distorting the output, so long as the data rate is 9600 Baud or less.

3-18. COUNTERS.

3-19. OSCILLATOR COUNT-DOWN - The four counters on the A7 card are binary four stage units each dividing by sixteen. The oscillator rate was chosen to be a high factor of 75×2^n Hz to allow use of a small crystal can and other small components in the oscillator. The counters have the driving side of each flip-flop presented on module pins so that each output is 75×2^n Hz. All factors from 75×2^0 through 75×2^{16} are available on the back plane wiring at the pins shown in the logic diagram (figure 6-2) but only the 75 Hz through 4800 Hz are brought out to the data rate switch.

3-20. BIT COUNTER - The Bit Counter is composed of the flip-flops BCO through BC5. The flip-flops are connected in a register configuration with feedback through XA11-6 to steer the front end. This type of connection is called a ring counter and has only one of its Q outputs high at any time with the rest low; (see the timing diagrams in figure 6-2). The six flip-flops and the feedback gate form a seven stage divide-by-seven counter. The six flipflops form a synchronous counter and are driven in parallel by the data clock chosen.

3-21. The Q output of each flip-flop drives a control input to a gate on XA33 so that only one gate output at a time may be at "0" level; the gate output is only enabled by the control flip-flop, its data input and the common control input from XA15-42 must also be high in order for a gate output to drive low at its turn. Before START, all selected channels output "letters" until the program begins; this functions as a "motor-turn-on" signal to the selected page printers. The "letters" character is continuously repeated until the "START" is initiated. The motor control will remain on until five minutes after the last data transition then turns itself off. (Refer to Commercial Manual MC110 for motor start units.)

3-22. The five data inputs are presented to the gates in parallel from a particular program card and its module-in-control. The order of the program card and modules thereon is controlled by the character counter, the program position counter, and the select position register. The common control input to the gates is normally high but goes low when the output is generated by the TD or by the KB instead of the internal program cards and modules. Whichever data source is in use the common gate output is driven through XA8 -6. The output at XA8 -6 is common false data so it is fed to the inverting inputs of the output interface sections selected to yield a true polar signal.

3-23. As shown in the timing/logic diagram (figure 6-2) the step pulse for driving external data sources, (TDs and KBs), is generated at character intervals. The necessary 1. 5 bit

interval is achieved by initiating the leading edge of the step pulse at the clock edge and ending the pulse on the second succeeding clock edge. Use of the step pulse is determined by the output control circuits.

3-24. CHARACTER COUNTER - The Character Counter (CC) is driven by the negative, trailing edge of BC5 in order that all character-module switching can be accomplished during the stop-bit interval of the last character read out. The CC is initially reset by the clear line so that all flip-flop Qs are low except CC1 where Q is taken as the true output. This configuration puts a single (1) in the ring counter, at clear time, which is propagated through the chain to CC16 and then recycled back to CC1 through XA15-23 and XA15-27. The timing diagram shown in figure 6-2 above the CC logic diagram shows the relationship described above.

3-25. Some of the circuits require CC pulses and some CC pulses so both are presented where necessary by using power inverters to prevent overloading. The CC determines only the character order in a line, so its outputs must be logically combined with other timing signals to derive unique program positions for the characters.

3-26. The CC is started when the START button is depressed and does not stop until next CLEAR time or power shut down except when the KB is in use. When the KB is in use, Cc stops in position CC14 and awaits the KB complete (KB COMPL) to enable it, whereupon finishes the sequence to CC16, giving the PPC an incrementing pulse, and starts over again: CC runs continuously during TD output and serves as an interval timer for the EOM detector. The EOM1 flip-flop is reset by each start bit that occurs on the common data line so that CC1 can never trigger EOM2 unless an interval encompassing two CC1 pulse occurs without an EOM1 reset.

3-27. PROGRAM POSITION COUNTER - The Program Position Counter (PPC) determines the program order and therefore the line order of the output. The PPC is a binary ripple counter composed of four individual flip-flops. The four flip-flop implementation eliminates the need for several inverters if a counter module were used. PPC is incremented by the BC5 edge, appearing in CC16 interval, by an HSC pulse in PC13 position when KB is not used or when it is relinquished, or by HSC pulses from the SPR controls when a selector position is skipped. Several positions are detected using a 4-input gate for each position. Use of these detected positions will follow in the sections describing the use circuits.

3-28. REGISTER.

3-29. The Selected Position Register (SPR) shown in figure 6-5, Logic Diagram, Channel Control, determines the starting address and the order of the information addresses. SPR is organized as a ring counter similar to CC. The SPR

has eleven positions, one for each of ten addresses and one for the KB. When the system is CLEARED, SPR is at rest in position 1 but when the AA button is depressed, HSC drives SPR from XA9-25 until an address selection is made and SPR reaches the corresponding position. At this time, a negative edge appears at XA17-10 setting AA2 and inhibiting further HSC pulses from XA9-25 (AA2 in set position enables II). SPR is now resting on the selected AA position and will not move again until the end of the second program line. The order of address outputs is always identical but the starting point varies.

3-30. When CC16 occurs at PPC2, SPR is incremental by a BC5 pulse from XA9-8. If the next position is selected, SPR will be incremented by CC16 at PPC3, etc; when any next position has not been chosen, XA9-10 goes high and SPR is driven with HSC from XA9-7 until the next selected position is found and XA9-10 is taken low inhibiting HSC. Whenever SPR skips an unselected position, HSC from XA9-7 also drives PPC causing it to skip as many program positions as SPR skips selector positions.

3-31. SELECTOR CONTROL.

3-32. A Selector Control Driver (SCD) receives inputs from the SPR in its turn, from its select control flip-flop when chosen, and from XA32-55 the common input used to hold all SCD outputs high until the second program line. When all inputs are high, an SCD output will go to (0), enabling its program card. When the program card is thus enabled with a (0) on its card control input, CC8 through CC14 character pulses enable its character modules, each in turn, to drive the common bit lines to the output gates. The gate operation is described above in paragraph 3-21. Only one module of one card is driving the common bit lines at any time.

3-33. The select control flip-flop is also coupled to a logic input to the companion polar input interface. This connection combines the address select control flip-flop with the "READY" input from the receiving page printer in an "and" configuration such that the selected channel lamp will not light unless both "READY" and the address select control flip-flop are high. The selected address channel will output a signal to the addressed page printer but the operator is warned that the signal is not being utilized. The lamp may delay lighting until the addressed page printer motor has started. Each address select control flip-flop (SCFF) is connected to the companion output interface circuit. The output is initially disabled but when the address has been selected, the common data drives the inverting input and all data is sent to the addressee page printer.

3-34. The address select control flip-flops are initially cleared to the unselected position. When an address select button is depressed, the negative signal edge appearing at the clock input to the select control flip-flop causes the flip-flop to trigger to the "SELECT" position.

The flip-flop is steered by the ERASE controls XA20-42 and XA20-55 until the START button has been depressed. After START the ERASE gates are driven high by S2 going low so that no further address changes may be made.

3-35. If an undesired address is selected, it may be erased by depressing the ERASE button. This inverts the steering inputs to the address selector flip-flop and turns off all the lamp drivers so that when the undesired address button is depressed the negative edge will trigger the undesired SCFF back to the reset, unselected position. A delay is necessary, between resetting the undesired flip-flop and relighting the correctly selected lamps, to prevent all flip-flops from being reset. This delay is accomplished by using step pulse to trigger the Erase Control flip-flops.

3-36. The SCKB flip-flops and gates provide the means to program the keyboard for use in the AA line or in line 13, the last II line. SCKB1 can be set only during the AA setup interval and is inhibited at all other times because XA13-16 holds the steering gate high. SCKB1 can be erased the same as any other address select control flip-flop. SCKB2 may be set during the II setup time and may not be erased but the operator may invalidate it by depressing the KBC button when the keyboard light comes on in line 13. The extra gating around the SCKB flip-flops allows use of a single KB button to set either or both SCKB flip-flops and to combine the status of the two SCKB flip-flops onto a single line (Y), each at the proper program position.

3-37. The KBCL flip-flops provide the means to return program control to SAMDS after keyboard use is complete. KBCL1 is associated with SCKB1 and KBCL2 with SCKB2. When a KBCL flip-flop is keyed, it disables its gate from driving a (0) into XA13-25(23) thus causing Y to return low. The trigger gating is logically combined, such that if only one SCKB flip-flop has been selected the KBCL lamp remains lit after KBCL is used. If both SCKB flip-flops have been chosen the KBC L lamp will stay lit only while the button is depressed after keyboard use on line 2 (AA) but will remain lit after keyboard use on line 13.

3-38. TURRET CONTROLS.

3-39. Turret controls consist of the serial number thumbwheels, the TD selector, the data rate switch, the address selector pushbuttons and the operational pushbuttons; the push-buttons are also indicators for their functions. A power indicator is located near the top of the turret control panel which should glow brightly indicating presence of both +6 Vdc and -6 Vdc (see figure 2-4).

3-40. The thumbwheels are each a single pole, ten position switch. The input to each switch is driven by an open-collector gate enabled by CC11 through CC16 in turn, during program line one (PC1). The 0 outputs of all six switches are tied in common to the

control input of a program module set up for 0. The 1's, 2's through 9's are likewise connected to their respective program modules. Any thumbwheel can drive any selected number without interference from the other thumb wheels because only one thumbwheel is driven at a time and only that one can cause an activating (0) to drive the number module chosen by its setting. The common pull-up resistors insure proper noise immunity.

3-41. The TD selector switch is a 2 form C unit which directs the selected TD output to the common dataline and applies +6V, -6V and +120V to the selected TD. The right end of the Logic Diagram, Timing Control (figure 6-2), shows the complete circuit connection.

3-42. The data rate switch is an eleven position switch using the first eight positions to present the required internal and external frequency sources for use as data clock.

3-43. The operation of the seventeen pushbuttons and the TD indicating lamp have been explained above.

3-44. PROGRAM CARD USE.

3-45. There are thirteen program cards used in SAMDS. Ten are used to generate address sequences and have been discussed above under programming. The remaining three cards supply the means to generate the fixed program format sequences. The ten numbers required by the serial number sequence, the characters A, I, N, R, RS, LF, CR, and SP are required in the fixed portion of the program. Since some of the symbols appear more than once in the program, the control logic connections between the CC and/or PPC timing counters and the much-used module (i.e., space) gets cumbersome; using the program format (figure 2-5) and the timing diagrams that appear on Logic Diagram, Timing Control (figure 6-2). It can be seen that each multi-use character is driven by an "OR" circuit driven by two or more "AND" control gates.

3-46. The program card schematic is shown on the left end of the Logic Diagram, timing control (figure 6-2). Each program module is driven by a two input NOR circuit which requires both input low to yield a high output. A high NOR output drives the program-module diode-cluster commoned-anodes high, thereby forcing all data bit lines, connected to uncut program module pins, high. As explained earlier, a high level on an output gate data input yields an output space level in that gate's turn. The program module driver outputs are normally low and only one is high at any character position during the program format.

3-47. INPUT/OUTPUT CONTROL.

3-48. Input/Output Control is achieved using flip-flop OC1 and OC2 with the Y line.

If Y goes high, step pulse is fed to the keyboard, the keyboard signal feeds the common data line and the output gates are disabled by the low at XA9-24.

3-49. OC1 is normally at rest high and is keyed low during PC13 and PC14 by the negative edge of CC4. OC1 is reset high by CC16. When OC1 is low, the output gates are held high so that the TD or keyboard can drive the common data line. The important use of OC1 is during PC14 where it inhibits the output gates at CC4 time causing a mark to appear on all data outputs until the TD begins sending at CC7 due to OC2. The delay between CC4 and CC7 is designed into the system in order to divorce the program bit timing from the TD bit timing. The delay removes the necessity to compensate for unique step-pulse to character release relationships caused by machine anomalies.

3-50. OC2 flip-flop enables step pulse to the selected TD and causes the TD indicator lamp to turn on. The TD lamp remains on until EOM is detected then is turned off.

3-51. POWER SUPPLIES.

3-52. There are two power supplies in SAMDS, +6 Vdc and -6 Vdc. The fuses are wired so that the center hole in the cap is the load side; use this cap hole when adjusting the power supply output voltages. The power supply adjustments face the front of the power supply rack for easy access. Use the Lambda manuals for understanding the power supply circuitry.

3-53. A third power supply, provides 130 Vdc required by the TD clutch magnet drivers.

SECTION 4 MAINTENANCE

4-1. GENERAL.

4-2. This section contains information for maintaining the SAMDS and troubleshooting the rare malfunction or breakdown. Power supply voltages should be checked periodically since aging can cause minor changes.

4-3. TEST EQUIPMENT.

4-4. Since the SAMDS is essentially a generator, only two pieces of equipment are needed for complete checkout and troubleshooting. Equivalent items may be substituted.

- a. Oscilloscope, Tektronix Type 535A
- b. Voltmeter, Triplett Model 630

4-5. REPAIR INSTRUCTIONS.

4-6. Servicing of this equipment requires adherence to the general rules of good shop practice. Since teflon wire insulation is used on all wire in the unit, there is no need to be concerned with the insulation melting when touched with a soldering iron. When printed circuit boards are repaired, a faulty component should be replaced by following the instructions below:

- a. Cut the leads to the component on the component side of the printed circuit board if possible.
- b. Using a 37-1/2-watt soldering iron, remove the remaining portion of the lead from the land.
- c. Place the new component in position, trim the leads if required, and solder it to the board.

4-7. PERFORMANCE TESTS.

4-8. Using the associated monitor page printer and keyboard, initiate a program with the KB only chosen from AA and II; follow instructions in paragraph 2-16 and use a test tape in the selected TD; the successful print-out proves the program and controls. If possible use programs using each address in the AA and II positions in order to prove the channel wiring and motor starters. The selected address light will not remain lit if the channel is not in proper operating condition.

4-9. TROUBLESHOOTING.

4-10. In all cases of malfunction check power supply levels at the fuse cap holes for +6V and -6V; on the card cage recheck the +6V, -6V, Vcc (+5V) and ground buses. If voltages are proper, measure period of the data rate in use with the oscilloscope; if incorrect, check the counter chain leading toward the oscillator. If the data rate is correct, monitor the counters for correct waveform moving toward the lower rates.

4-11. If all the timing appears normal, check the site of the malfunction using the logic diagrams and explanations as a guide.

4-12. Figure 6-6 is useful for locating malfunctioning modules.

Table 4-1. Troubleshooting Chart

SYMPTOM	POSSIBLE CAUSE	CHECK
+6V or -6V low	a. Low primary power b. Faulty printed circuit card	117 Vac lines Remove A13 and A14 cards, one at a time until voltage returns to nominal.
+6 only	a. Vcc is overloaded b. Cable short	Remove one end of R on A5TB1 Clear SAMDS to reduce lamp requirements; press each light button to find fault.
Vcc low	a. Faulty card b. Shorted card cage pins	Remove and firmly reseat all cards while monitoring Vcc for return to nominal when faulty card is removed. Visually inspect backplane wiring
Faulty card	a. Short on card b. Faulty module	Visually inspect for shorts. Higher than normal temperature when power is removed.
Pushbutton will not glow	a. Blown bulb b. Signal path open	Try bulb in socket of a good bulb. Replace cards in signal path shown on schematic.

Table 4-1. Troubleshooting Chart (Cont)

SYMPTOM	POSSIBLE CAUSE	CHECK
Pushbutton will not glow (Cont)	c. PagePrinter ready line open.	Open "ready" line at tag block; put local side to +6V.
Serial number does not print properly	a. Faulty number unit b. Faulty A10 card	Do performance test, exercise bad unit. Remove and reseat firmly or replace.
Improper Data Rate	a. Faulty rate switch b. Faulty counting step	Exercise the switch see that each position has one-half or twice the rate of the adjacent position. Monitor the counters on A7, see that each rate step from the oscillator is dividing by 2.
Improper Data Format	a. Bit Counter faulty	Synchronize oscilloscope on XA12-16, monitor Q of each Bit Counter flip-flop See waveform diagram near Bit Counter on schematic.
Improper Program Format	a. Character Counter faulty b. Program Position Counter faulty	Synchronize oscilloscope on XA6-20 (CC1) check all CCQs. See waveform on schematic. Synchronize oscilloscope on XA6-3 check all PPC Qs for ripple binary counter sequence; use all 10 address selections and both KB (AA and II) selections to ensure good waveform.

SECTION 5 PARTS LIST

5-1. INTRODUCTION.

5-2. This section contains the Parts Lists, table 5-1, of the electrical components used in the Semiautomatic Message Distribution System. The parts listings are divided into the following nine sections.

- Basic Cabinet Components
- Circuit Card Assembly Turret Connector - A15
- Circuit Card Assembly Tag Block Connector - A16
- Circuit Card Assembly Polar Interface - A13
- Circuit Card Assembly Extender
- Circuit Card Assembly AUX - A14
- Circuit Card Assembly Diode Expander - A11
- Circuit Card Assembly Program - A12
- Circuit Card Assembly Universal Logic - A1 through A10

5-3. The first three items listed under Circuit Card Assembly Universal Logic - A1 through A10 noted by the asterisk, are common to all ten boards. The reference designation for these items, noted by the double asterisk, must be prefixed with the board designation when referring to a specific board component.

Table 5-1. Parts Lists

QTY REQD	PART OR IDENTIFYING NO	DESCRIPTION	REFERENCE DESIGNATION
<u>BASIC CABINET COMPONENTS</u>			
6	49900-400	Selector, Switch (Durant)	A3S19 thru S24
1	MST-215N	Switch, Toggle (Alco)	A3S25
1	4028277-0701	Light, Indicator	A3XDS19
1	183-9830-14-604	Base Assembly-Indicator Light (Dialight Corp)	A3XDS18
17	513-0101-604	Base Assembly- (Dialight Corp)	A3S1-S17 A3XDS1-XDS17
1	CSR13C227KL	Capacitor, Mil-C-390031	A4C1
2	2003919-0503	TD Modification	A1,A2
1	LCS-1O1A	Power Supply (Lambda)	A5PS2
1	LCS-A6	Power Supply (Lambda)	A5PS1
1	MS35059-22	Switch, Toggle	A5S1
1	132-0410-0995-201	Light, Indicator (Dialight Corp)	A5XDS1
1	746	Lamp (G. E.)	A5DS1
3	HKP-11	Holder, Fuse (Bussman)	A5XF1, 2 & 3
1		Fuse	A5F1
1		Fuse	A5F2
1		Fuse	AF3
1	355-11-09-001 602C-9	Strip, Terminal (Cinch Kulka)	A5TB1
2	4031489-0501	Circuit Card Assembly - 16 x 2 Inp Nand Gates	A4A1
2	4031489-0502	Circuit Card Assembly - 8 x 4 Inp Expand Nand Gates	A4A2
5	4031489-0503	Circuit Card Assembly - 8 RS/T Flip-Flop	A4A3
1	4031489-0504	Circuit Card Assembly - 4 x 8 Bit Shift Register	A4A4
1	4031489-0505	Circuit Card Assembly - 24 Inverter - High Power	A4A5
2	4031489-0506	Circuit Card Assembly - 12 x 3 Inp Nand Gates	A4A6
1	4013489-0507	Circuit Card Assembly - 4 x 6 Counter	A4A7
1	4031489-0508	Circuit Card Assembly - 24 Inverter - Low Power	A4A8

Table 5-1. Parts Lists (Cont)

QTY REQD	PART NO. IDENTIFYING NO	DESCRIPTION	REFERENCE DESIGNATION
<u>BASIC CABINET COMPONENTS</u>			
1	4031489-0509	Circuit Card Assembly - 16 x 2 Inp Nands Gates - Hi Power	A4A9
1	4031489-0510	Circuit Card Assembly - 12 x 3 Inp Nand Gates - Open Coll.	A4A10
1	2057908-0501	Circuit Card Assembly - Diode Expander	A4A11
13	4031480-0501	Circuit Card Assembly - Program	A4A12
7	2057910-0501	Circuit Card Assembly - Polar Interface	A4A13
1	4031482-0501	Circuit Card Assembly - Aux	A4A14
1	4031484-0501	Circuit Card Assembly - Turret Conn	A4A15
1	4031486-0501	Circuit Card Assembly - Tag Blk Conn	A4A16
1	4031488-0501	Circuit Card Assembly - Extender	
1	2058075-0701	Block, Term	TB1
1	71590 PAI001	Switch, Rotary (Centralab)	A3S18
18	345	Lamp - Incandescent	A3DS1-DS18
1	4014354-0702	Lamp	A3DS19
42	HW31DO-111	Connector (Winchester)	A4XA1 thru A4XA42
1	TT152950	Power Supply Teletype	A5PS3
1	RCR32G223JM	Resistor Mil-R-39008/1	A5TBiR1
1	44655 2822	Resistor, 1 ohm (Ohmite)	A5TB1R2
118	18324 N8731A	Module, Integrated Circuit	
<u>CIRCUIT CARD ASSEMBLY</u>			
1	4031487-0001	Printed Wire Board	
1	HW31DO-111	Connector (Winchester)	
<u>CIRCUIT CARD ASSEMBLY TAG CLOCK CONNECTOR A-16</u>			
1	4031487-0001	Printed Wire Board	
1	HW31DO-111	Connector (Winchester)	

Table 5-1. Parts Lists (Cont)

QTY REQD	PART NO. IDENTIFYING NO.	DESCRIPTION	REFERENCE DESIGNATION
<u>CIRCUIT CARD ASSEMBLY POLAR INTERFACE - A13</u>			
1	2057909-0001	Printed Wire Board	
2	RCR07G272JM	Resistor Mil-R-39008/1	A13R1,A13R3
2	RCR07G470JM	Resistor Mil-R-39008/1	A13R2,A13R4
3	8121-050W5R- 103M	Capacitor Erie	A13C2,A13C3, A13C6
2	8121-050-W5RO- 102M	Capacitor Erir	A13C4,A13C5
3	CSR15B565KL	Capacitor Mil-C-39003/1	A13C1,A13C7, A13C8
2	IEE-33	Lamp, Ballast (IEEE)	A13RT1,A13RT2
2	μ E-235B	Module, Integrated Circuit Inp Amp	A13A1,A13A4
2	μ E-251A	Module, Integrated Circuit Polar Driver	A13A2,A13A5
2	N8480A	Module, Integrated Circuit (Signetics)	A13A3,A13A6
<u>CIRCUIT CARD ASSEMBLY EXTENDER</u>			
1	4031487-0001	Printed Wiring Board	
1	81312 HW31DO-111	Connector (Winchester)	
<u>CIRCUIT CARD ASSEMBLY AUX-A14</u>			
1	4031481-0001	Printed Wiring Board	
1	04713 MC1712CG	Module, Integrated Circuit Op Amp (Motorola)	A14A1
1	07668 2N706	Transistor	A14Q1
1	CR60A/U, 4.9152 MHz, HC-18	Crystal (Hunt)	A14Y1
6	07668 1N914	Diode, Silicon	A14CR1 thru A14CR6
5	18796 8121-100-W5RO- 102M	Capacitor	A14C 1, A14C2, A14C5,A14C6, A14C7
3	CSR13B565KL	Capacitor Mil-C-39003/1	A14C8,A14C9, A14C10

Table 5-1. Parts Lists (Cont)

QTY REQD	PART NO. IDENTIFYING NO.	DESCRIPTION	REFERENCE DESIGNATION
<u>CIRCUIT CARD ASSEMBLY AUX-A14 (Cont)</u>			
1	18796 8121-100-W5RO- 102M	Capacitor	A14C4
1	DM10F-500J	Capacitor (Elmenco)	A14C3
1	RCR07G102JM	Resistor Mil-R-39008/1	A14R1
1	RCR07G182JM	Resistor Mil-R-39008/1	A14R2
1	RCR07G331JM	Resistor Mil-R-39008/1	A14R3
2	RCR07G560JM	Resistor Mil-R-39008/1	A14R4,A14R5
2	RCR07G222JM	Resistor Mil-R-39008/1	A14R6, A14R21
1	RCR07G221JM	Resistor Mil-R-39008/1	A14R7
1	RCR07G122JM	Resistor Mil-R-39008/1	A14R8
1	RCR07G101JM	Resistor Mil-R-39008/1	A14R9
5	RCR07G333JM	Resistor Mil-R-39008/1	A14R10,A14R12, A14R14, A14R16, A14R18
5	RCR07G472JM	Resistor Mil-R-39008/1	A14R11,A14R13, A14R15, A14R17, A14R19
1	RCR07G183JM	Resistor Mil-R-39008/1	A14R20
<u>CIRCUIT CARD ASSEMBLY DIODE EXPANDER -A11</u>			
1	2057907-0001	Printed Wiring Board	
6	RCR07G392JM	Resistor Mil-R-39008/1	A11R1,A11R2, A11R3, A11R4, A11R5,A11R6
1	18796 8121-050-W5R- 103M	Capacitor (Erie)	A11C2
1	CSR13B565KL	Capacitor Mil-C-39003/1	A11C1
4	18324 N8731A	Module, Integrated Circuit (Signetics)	A11A1,A11A2, A11A3,A11A4
<u>CIRCUIT CARD ASSEMBLY PROGRAM - A12</u>			
1	4031479-0001	Printed Wiring Board	
2	18324 N8885A	Module, Integrated Circuit (Signetics)	A12A8,A12A9

Table 5-1. Parts Lists (Cont)

QTY REQD	PART NO. IDENTIFYING NO.	DESCRIPTION	REFERENCE DESIGNATION
CIRCUIT CARD ASSEMBLY PROGRAM - A12			
7	91506 314-AG5D-2R	Socket, Integrated Circuit (Augat)	A12XA1 thru A12XA7
CIRCUIT CARD ASSEMBLY UNIVERSAL LOGIC - A1 THRU A10			
*10	2057905-0001	Printed Wiring Board	
*10	CSR13B565KL	Capacitor AMIil-C-39003/1	C1 **
*10	18796 8121-050-W5R- 103M	Capacitor	C2 **
4	18324 N8480A	Module, Integrated Circuit (Signetics)	A1A1, A1A2, A1A3, A1A4
4	18324 N8416A	Module, Integrated Circuit (Signetics)	A2A1, A2A2, A2A3, A2A4
3	07688 1N914	Diode	A2CR1, A2CR2, A2CR3
4	18324 N8424A	Module Integrated Circuit (Signetics)	A3A1, A3A2, A3A3, A:3A4
3	RCR07G472JM	Resistor Mil-R-39008/1	A3RA, A3RB, A3RC
4	27014 DM8570	Module, Integrated Circuit (National Semiconductor)	A4A1, A4A2, A4A3, A4A4
4	18324 N8H90A	Module, Integrated Circuit (Signetics)	A5A1, A5A2, A5A3, A5A4
4	18324 N8281A	Module, Integrated Circuit (Signetics)	A6A1, A6A2, A6A3, A6A4
4	18324 N8281A	Module, Integrated Circuit (Signetics)	A7A1, A7A2, A7A3, A7A4
4	18324 N8490A	Module, Integrated Circuit (Signetics)	A8A1, A8A2, A8A3, A8A4
4	18324 N8880A	Module, Integrated Circuit (Signetics)	A9A1, A9A2, A9A3, A9A4
4	18324 N8471A	Module, Integrated Circuit (Signetics)	A10A1, A10A2, A10A3, A10A4
3	RC07GF203J	Resistor, Mil-R-39008/1	A10R1, A10R2, A10R3

* See paragraph 5-3.

**SECTION 6
DRAWINGS**

6-1. GENERAL.

6-2. This section contains logic diagrams, schematics and mechanical configuration drawings.

6-1/(6-2 blank)

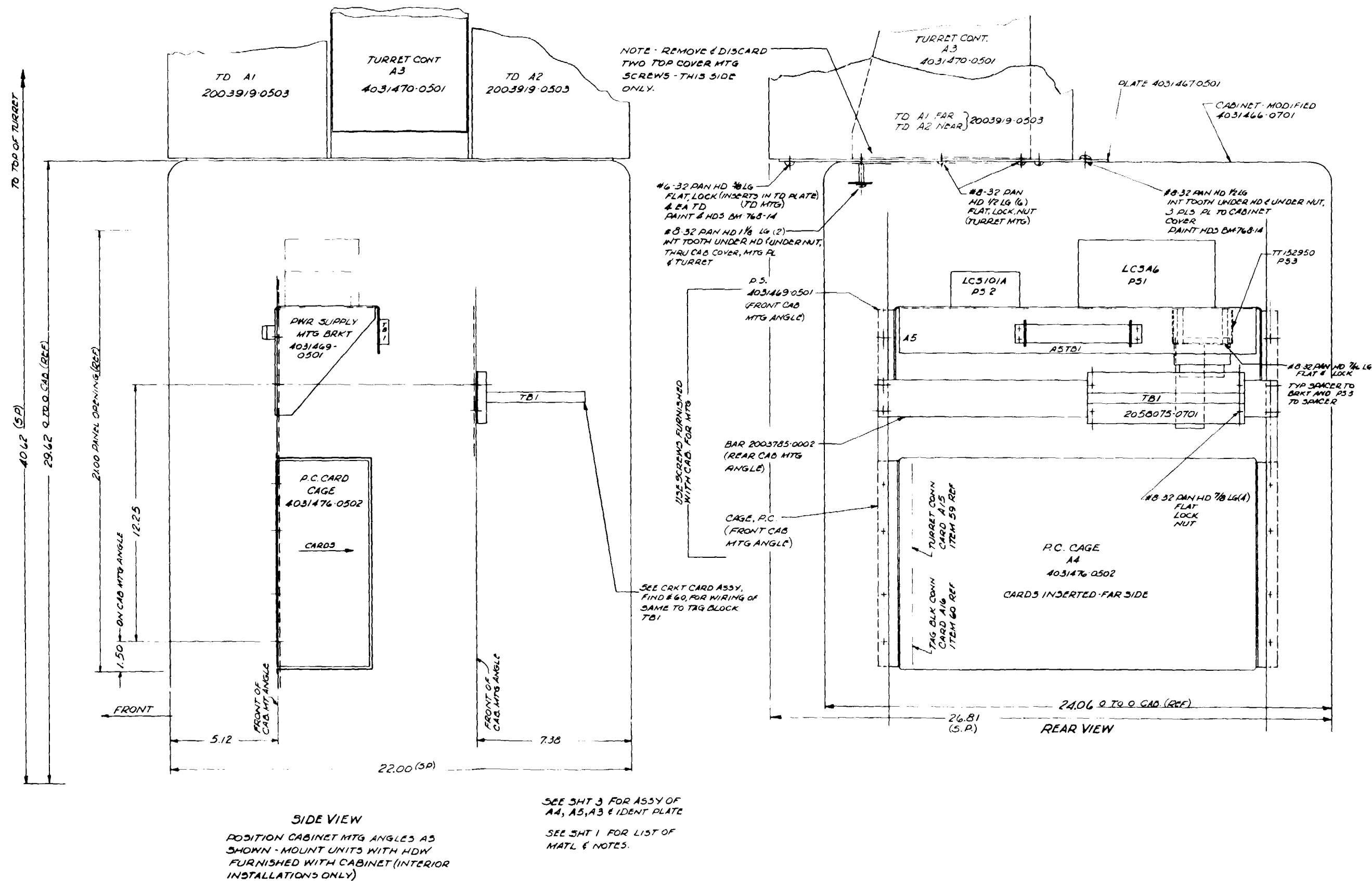
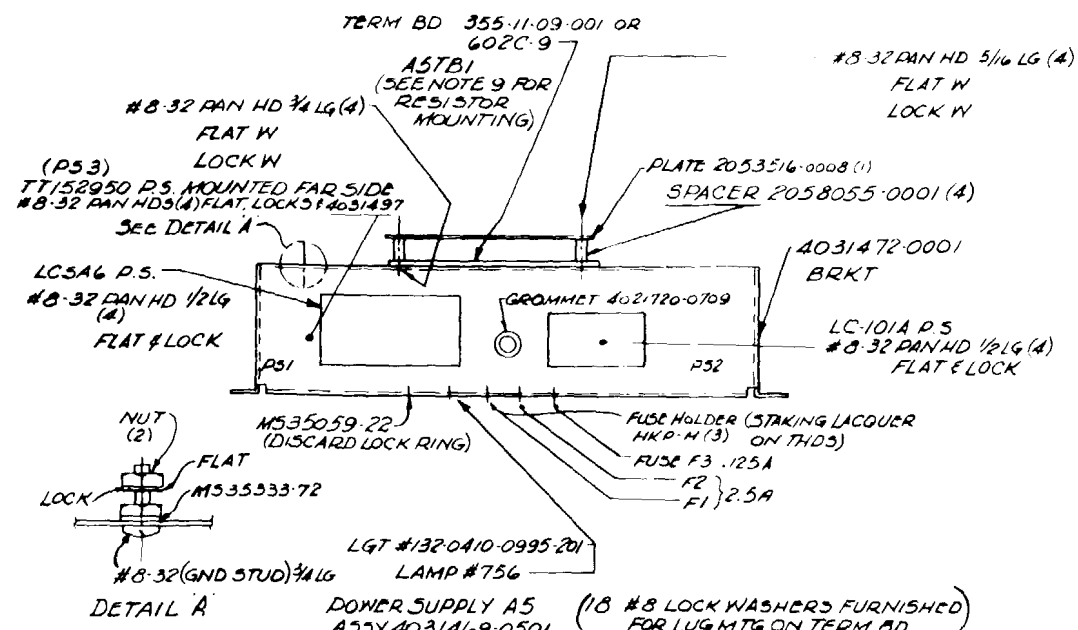
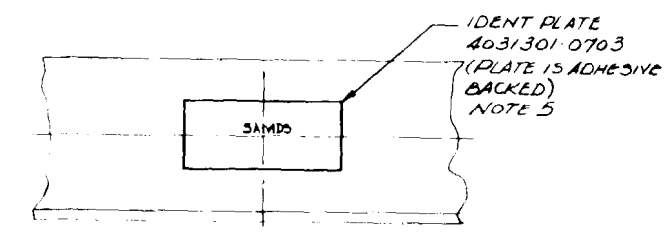
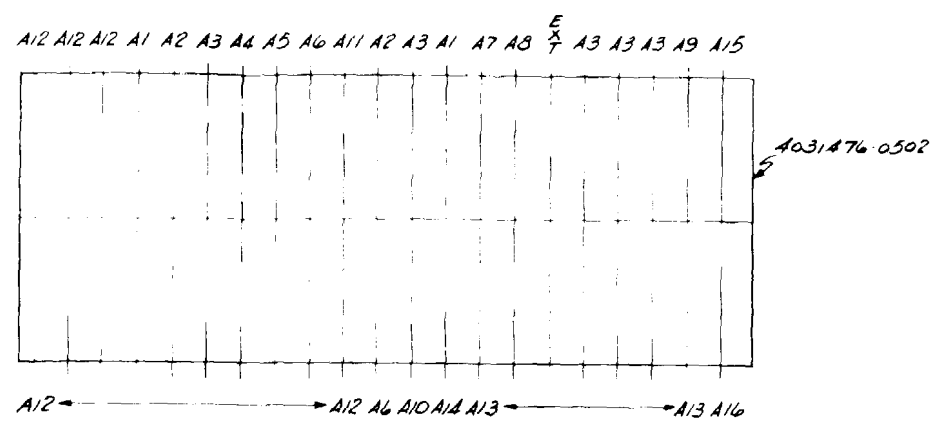

Figure 6-1. Semiautomatic Message Distribution System (Sheet 1 of 2)



DETAIL A
 POWER SUPPLY A5 (18 #8 LOCK WASHERS FURNISHED)
 ASSY 4031469-0501 FOR LUG MTG ON TERM BD



FRONT - TOP OF CABINET MOUNT PLATE ON CENTERS AS SHOWN

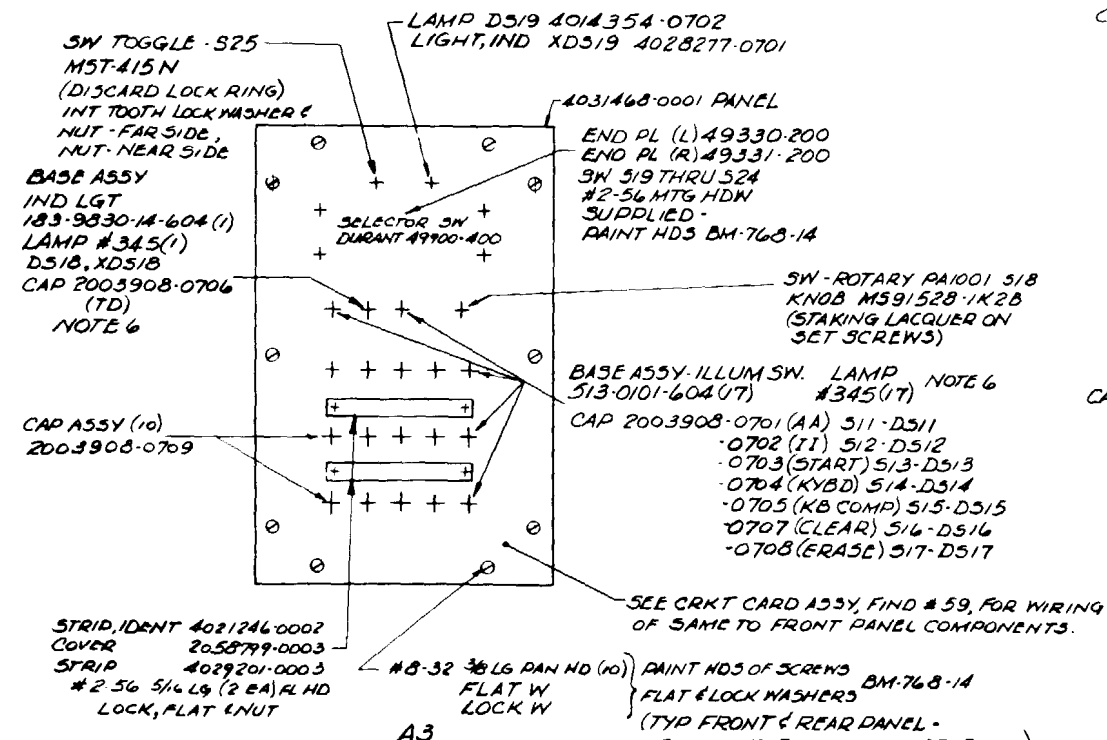

A3 FRONT PANEL TURRET
 MT REAR PANEL SAME HARDWARE
 ASSY 4031470-0501
 NOT SHOWN
 TURRET ASSY 2003902-0502
 COVER, REAR 2003907-0002

CARD	QTY	# STENCIL CARD ASSY
A1	4031489-0501 (2)	A1
A2	.0502 (2)	A2
A3	.0503 (5)	A3
A4	.0504 (1)	A4
A5	.0505 (1)	A5
A6	.0506 (2)	A6
A7	.0507 (1)	A7
A8	.0508 (1)	A8
A9	.0509 (1)	A9
A10	4031489-0510 (1)	A10
A11	2057908-0501 (1) DIODE EXPANDER	A11
A12	4031480-0501 (13) PROGRAM (NOTE 10)	A12
A13	2057910-0501 (7) POLAR INTERFACE	A13
A14	4031482-0501 (1) AUX	A14
A15	4031484-0501 (1) TURRET CONN	A15
A16	4031486-0501 (1) TAG BLOCK CONN	A16
CARD	4031488-0501 (1) EXTENDER	-

PCCARD CAGE A4
 INSERT CARDS IN SLOTS IDENTIFIED BY CARD REF DESIG.
 ASSY 4031476-0502
 * STENCIL GOTHIC TYPE CHARACTERS .12 ± .02 HIGH, IN BLACK. PER BM-865-4 ON COMPONENT SIDE.

Figure 6-1. Semiautomatic Message Distribution System (Sheet 2 of 2)

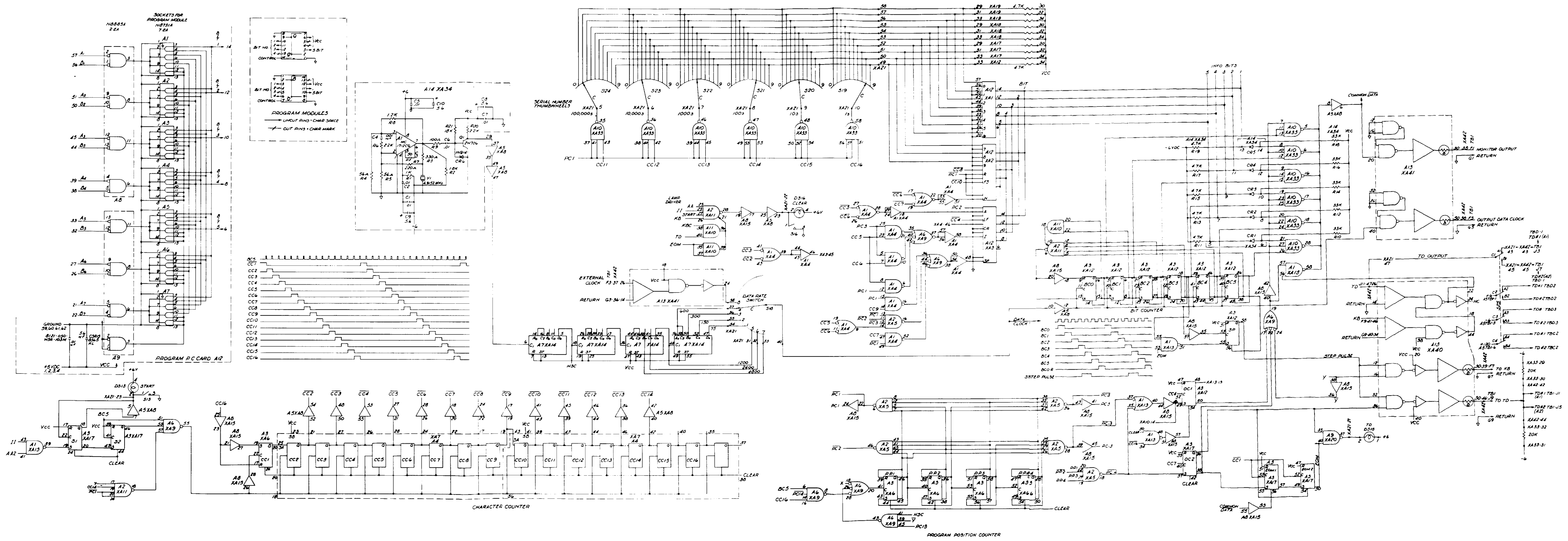
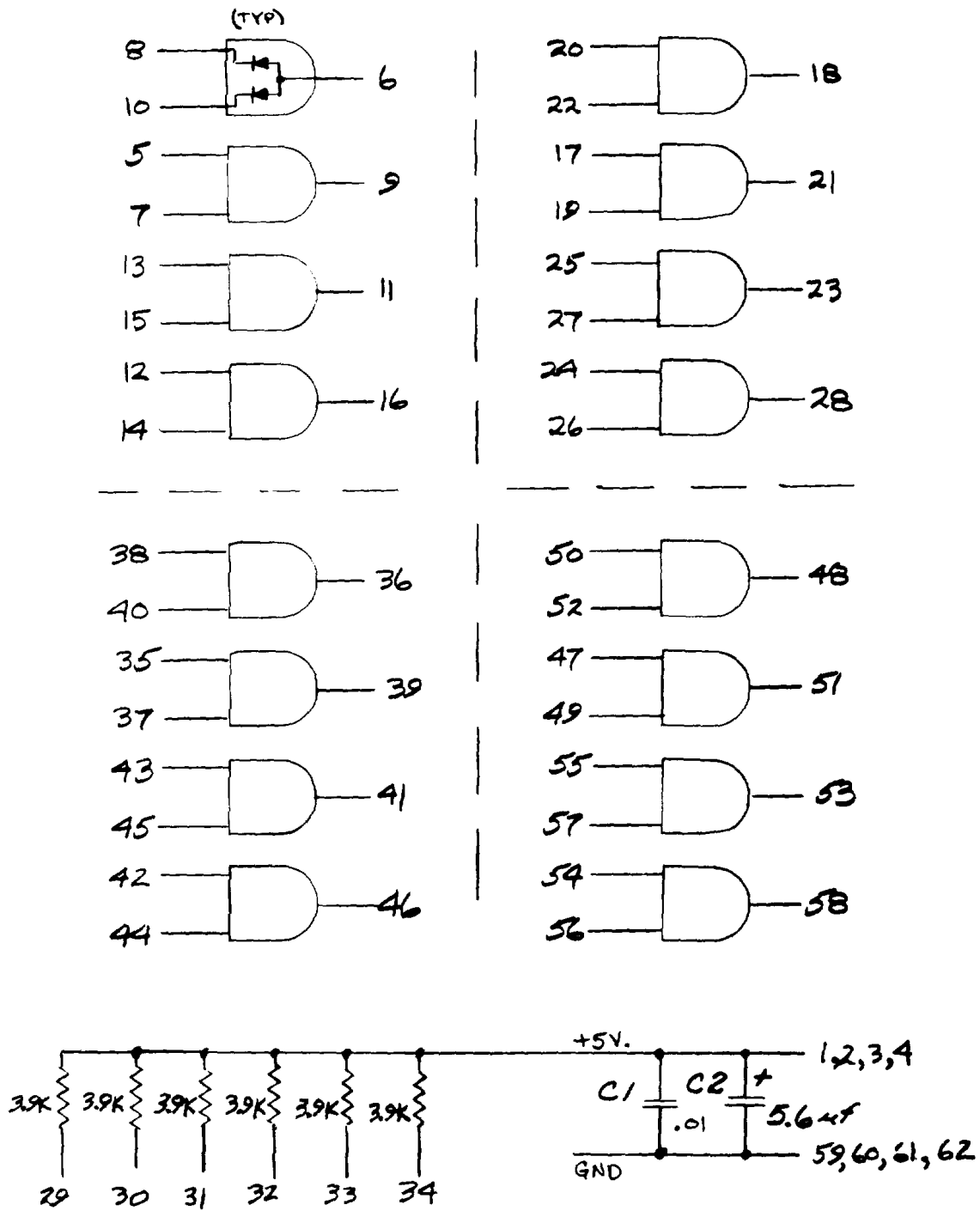

Figure 6-2. Logic Diagram, Timing Control 6-7/(6-8 blank)



CIRCUITS: FOUR SIGNETS N8731A
SIX 3.9K PULL-UP RESISTORS

DESCRIPTION: QUAD 2-INPUT DIODE EXPANDER ELEMENT
0 TO +75°C TEMP. RANGE
(USED WITH N8416A GATE, LOGIC
CARD TYPE 103)
PULL-UP RESISTORS USABLE WITH GATES
OF LOGIC CARD TYPE 106

LOADING: 1.5 DC LOAD PER INPUT

Figure 6-3. Schematic, Expander A4A11 Printed Circuit Board

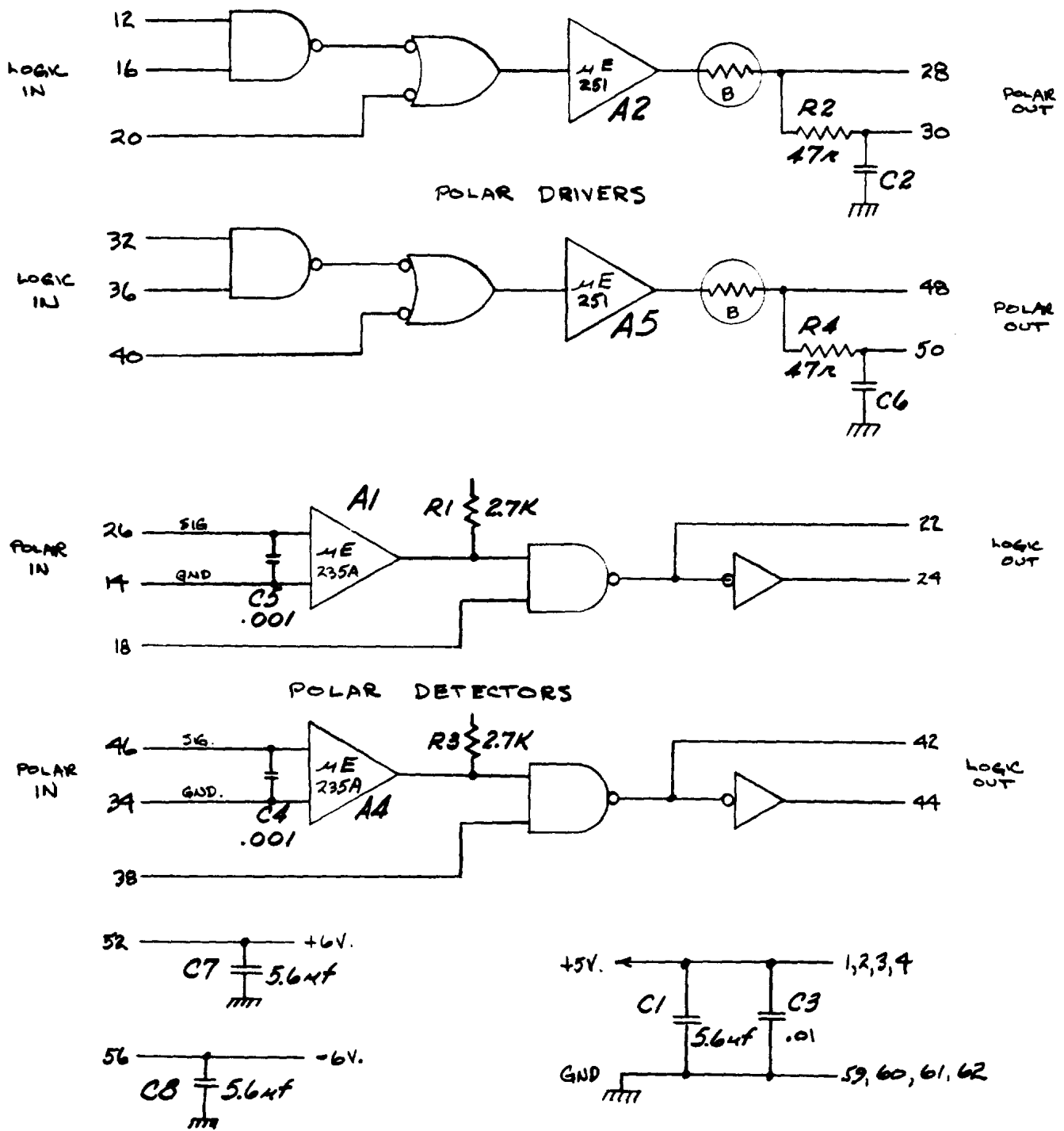

CIRCUITS: TWO SIGNETICS N8480A, TWO BENDIX $\mu E 235A$, TWO BENDIX $\mu E 251$.

DESCRIPTION: 2 POLAR DRIVERS, CONVERTING LOGIC LEVEL SIGNALS TO MIL-STD-188D INTERFACE LEVEL OUTPUT
 2 POLAR DETECTORS, CONVERTING MIL-STD-188B INPUT TO LOGIC LEVEL.
 CONTROL GATING INCLUDED AS SHOWN.
 WAVEFORM SHAPING COMPONENTS (*) MAY BE ADDED, VALUES ADJUSTED TO SUIT DATA RATE.

CURRENT DRAIN (AVG), PER CARD:
 +5 VDC - 21 mA
 +6 VDC - 30 mA
 -6 VDC - 30 mA TYPICAL

Figure 6-4. Schematic, Polar Signal Interface Printed Circuit Board

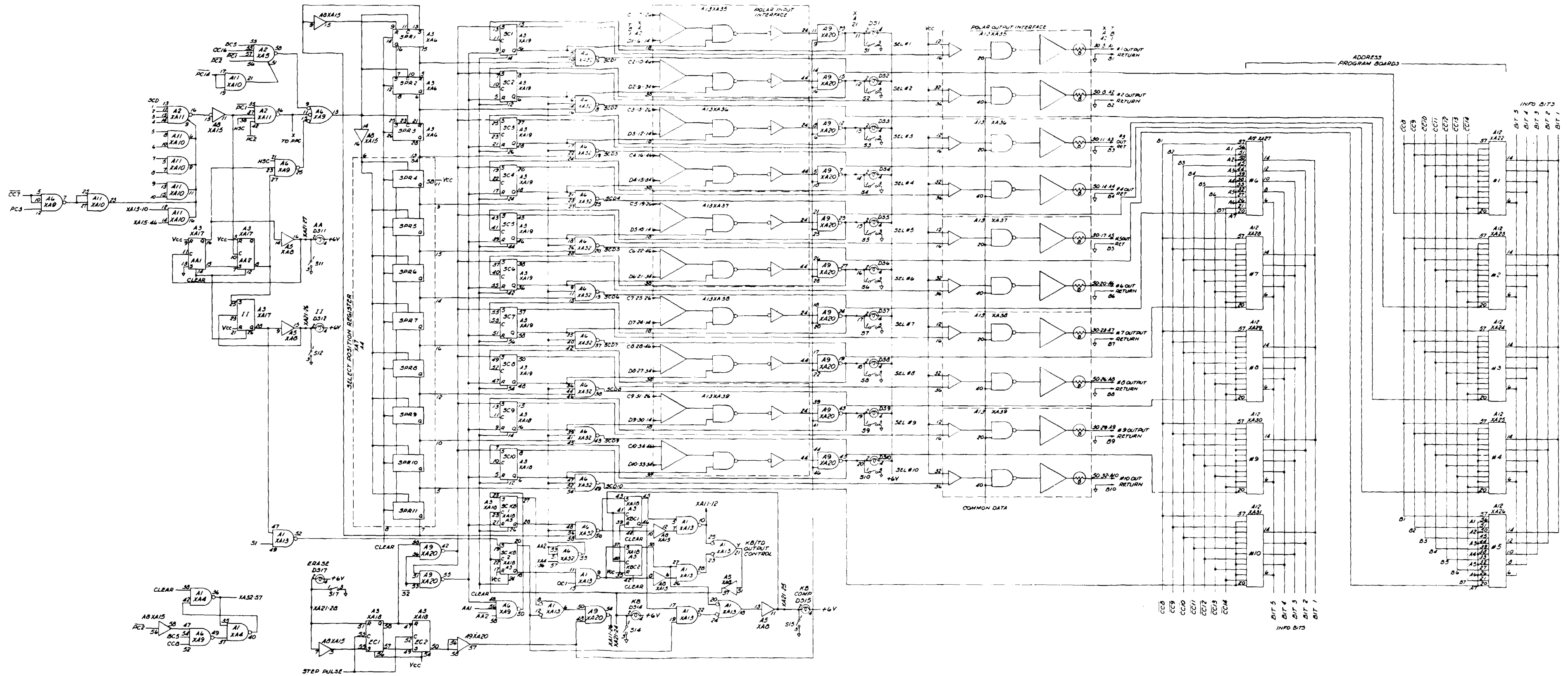

Figure 6-5. Logic Diagram, Channel Control
6-11/(6-12 blank)

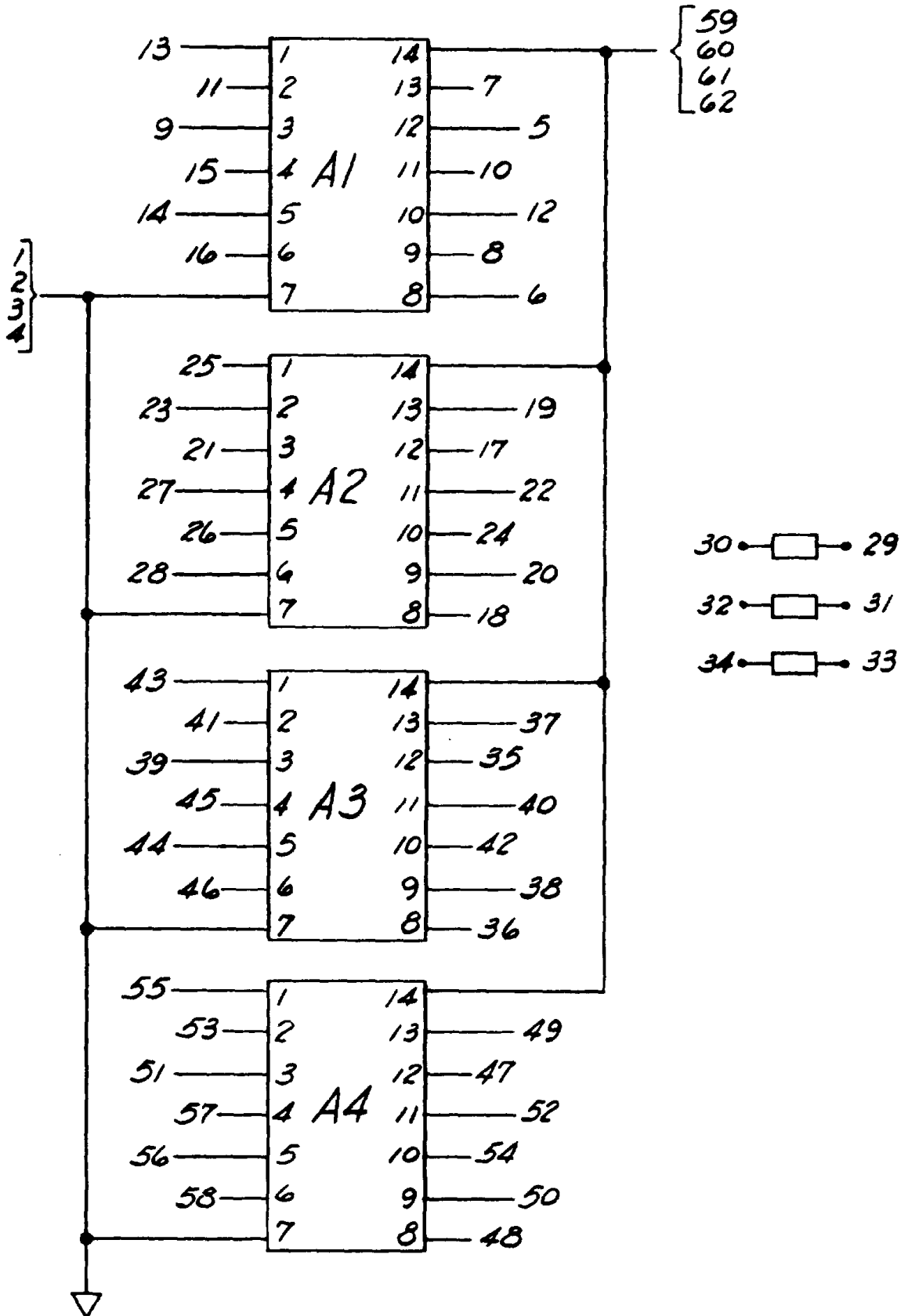

Figure 6-6. Schematic, Circuit Cards A1 Through A10
 6-13/(6-14 blank)

By Order of the Secretary of the Army:

Official:

VERNE L. BOWERS,
*Major General, United States Army,
The Adjutant General.*

W. C. WESTMORELAND,
*General, United States Army,
Chief of Staff.*

☆U.S. GOVERNMENT PRINTING OFFICE: 1972-769162/274

The Metric System and Equivalents

Linear Measure

1 centimeter = 10 millimeters = .39 inch
 1 decimeter = 10 centimeters = 3.94 inches
 1 meter = 10 decimeters = 39.37 inches
 1 dekameter = 10 meters = 32.8 feet
 1 hectometer = 10 dekameters = 328.08 feet
 1 kilometer = 10 hectometers = 3,280.8 feet

Weights

1 centigram = 10 milligrams = .15 grain
 1 decigram = 10 centigrams = 1.54 grains
 1 gram = 10 decigrams = .035 ounce
 1 decagram = 10 grams = .35 ounce
 1 hectogram = 10 decagrams = 3.52 ounces
 1 kilogram = 10 hectograms = 2.2 pounds
 1 quintal = 100 kilograms = 220.46 pounds
 1 metric ton = 10 quintals = 1.1 short tons

Liquid Measure

1 centiliter = 10 milliliters = .34 fl. ounce
 1 deciliter = 10 centiliters = 3.38 fl. ounces
 1 liter = 10 deciliters = 33.81 fl. ounces
 1 dekaliter = 10 liters = 2.64 gallons
 1 hectoliter = 10 dekaliters = 26.42 gallons
 1 kiloliter = 10 hectoliters = 264.18 gallons

Square Measure

1 sq. centimeter = 100 sq. millimeters = .155 sq. inch
 1 sq. decimeter = 100 sq. centimeters = 15.5 sq. inches
 1 sq. meter (centare) = 100 sq. decimeters = 10.76 sq. feet
 1 sq. dekameter (are) = 100 sq. meters = 1,076.4 sq. feet
 1 sq. hectometer (hectare) = 100 sq. dekameters = 2.47 acres
 1 sq. kilometer = 100 sq. hectometers = .386 sq. mile

Cubic Measure

1 cu. centimeter = 1000 cu. millimeters = .06 cu. inch
 1 cu. decimeter = 1000 cu. centimeters = 61.02 cu. inches
 1 cu. meter = 1000 cu. decimeters = 35.31 cu. feet

Approximate Conversion Factors

<i>To change</i>	<i>To</i>	<i>Multiply by</i>	<i>To change</i>	<i>To</i>	<i>Multiply by</i>
inches	centimeters	2.540	ounce-inches	Newton-meters	.007062
feet	meters	.305	centimeters	inches	.394
yards	meters	.914	meters	feet	3.280
miles	kilometers	1.609	meters	yards	1.094
square inches	square centimeters	6.451	kilometers	miles	.621
square feet	square meters	.093	square centimeters	square inches	.155
square yards	square meters	.836	square meters	square feet	10.764
square miles	square kilometers	2.590	square meters	square yards	1.196
acres	square hectometers	.405	square kilometers	square miles	.386
cubic feet	cubic meters	.028	square hectometers	acres	2.471
cubic yards	cubic meters	.765	cubic meters	cubic feet	35.315
fluid ounces	milliliters	29.573	cubic meters	cubic yards	1.308
pints	liters	.473	milliliters	fluid ounces	.034
quarts	liters	.946	liters	pints	2.113
gallons	liters	3.785	liters	quarts	1.057
ounces	grams	28.349	liters	gallons	.264
pounds	kilograms	.454	grams	ounces	.035
short tons	metric tons	.907	kilograms	pounds	2.205
pound-feet	Newton-meters	1.356	metric tons	short tons	1.102
pound-inches	Newton-meters	.11296			

Temperature (Exact)

°F	Fahrenheit temperature	5/9 (after subtracting 32)	Celsius temperature	°C
----	---------------------------	-------------------------------	------------------------	----

PIN: 019698-000